



NEPAL NATIONAL BUILDING CODE

NBC 109 : 1994



MASONRY : UNREINFORCED

Government of Nepal
Ministry of Physical Planning and Works
Department of Urban Development and Building Construction
Babar Mahal, Kathmandu, NEPAL
Reprinted : 2064



NEPAL NATIONAL BUILDING CODE

NBC 109 : 1994



MASONRY : UNREINFORCED

This publication represents a standard of good practice and therefore takes the form of recommendations. Compliance with it does not confer immunity from relevant legal requirements, including bylaws

तत्कालिन श्री ५ को सरकार (मन्त्रिपरिषद्) को मिति २०६०।४।१२ को निर्णयानुसार स्वीकृत

Government of Nepal
Ministry of Physical Planning and Works
Department of Urban Development and Building Construction
Babar Mahal, Kathmandu, NEPAL
Reprinted : 2064

Preface

This Nepal Standard was prepared during 1993 as part of a project to prepare a National Building Code for Nepal.

In 1988 the Ministry of Housing and Physical Planning (MHPP), conscious of the growing needs of Nepal's urban and shelter sectors, requested technical assistance from the United Nations Development Programme and their executing agency, United Nations Centre for Human Settlements (UNCHS).

A programme of Policy and Technical Support was set up within the Ministry (UNDP Project NEP/88/054) and a number of activities have been undertaken within this framework.

The 1988 earthquake in Nepal, and the resulting deaths and damage to both housing and schools, again drew attention to the need for changes and improvement in current building construction and design methods.

Until now, Nepal has not had any regulations or documents of its own setting out either requirements or good practice for achieving satisfactory strength in buildings.

In late 1991 the MHPP and UNCHS requested proposals for the development of such regulations and documents from international organisations in response to terms of reference prepared by a panel of experts.

This document has been prepared by the subcontractor's team working within the Department of Building, the team including members of the Department and the MHPP. As part of the proposed management and implementation strategy, it has been prepared so as to conform with the general presentation requirements of the Nepal Bureau of Standards and Metrology.

The subproject has been undertaken under the aegis of an Advisory Panel to the MHPP.

The Advisory Panel consisted of :

Mr. UB Malla, Joint Secretary, MHPP	Chairman
Director General, Department of Building	
(Mr. LR Upadhyay)	Member
Mr. AR Pant, Under Secretary, MHPP	Member
Director General, Department of Mines & Geology	
(Mr. PL Shrestha)	Member
Director General, Nepal Bureau of Standards & Metrology	
(Mr. PB Manandhar)	Member
Dean, Institute of Engineering, Tribhuvan University	
(Dr. SB Mathe)	Member
Project Chief, Earthquake Areas Rehabilitation & Reconstruction Project	Member
President, Nepal Engineers Association	Member
Law Officer, MHPP (Mr. RB Dange)	Member
Representative, Society of Consulting Architectural & Engineering Firms (SCAEF)	Member

**Representative, Society of Nepalese Architects (SONA)
Deputy Director General, Department of Building,
(Mr. JP Pradhan)**

**Member
Member-Secretary**

The Subcontractor was BECA WORLEY INTERNATIONAL CONSULTANTS LTD. of New Zealand in conjunction with subconsultants who included :

Golder Associates Ltd., Canada
SILT Consultants P. Ltd., Nepal
TAEC Consult (P.) Ltd., Nepal
Urban Regional Research, USA

Principal inputs to this standard came from :

Mr. AM Tuladhar, DoB, HMGN
Dr. AS Arya, Professor Emeritus, University of Roorkee, India
Dr. RD Sharpe, BECA (Team Leader)

Revisions and Updated to this code came from :

Mr. Purna P. Kadariya, DG, DUDBC
Mr. Kishore Thapa, DDG, DUDBC
Mr. Mani Ratna Tuladhar, Sr. DIV. Engineer, DUDBC
Mr. Jyoti Prasad Pradhan, Ex.DG, DOB
Mr. Bhubaneswor Lal Shrestha, Ex. DDG, DOB
Mr. Uttam Shrestha, Architect, Architects' Module Pvt. Ltd.
Mr. Manohar Lal Rajbhandhari, Sr. Structural Engineer, Mr Associates
Mr. Amrit Man Tuladhar, Civil Engineer, DUDBC

TABLE OF CONTENTS

Preface		i
0 Foreword		vii
0.1 Design Aspects Covered		vii
0.2 Related Codes		
1 Scope		1
1.1 Area Cover		1
1.2 Limitation		1
1.3 Provisions for Historical Buildings		1
2 Interpretation		1
2.1 General		1
2.2 Terminology		1
2.3 Symbols		2
3 Materials		3
3.1 Material Used		3
3.2 Masonry Unit		3
3.3 Tolerances		4
3.4 Classification of Bricks and Brickwork		5
3.4.1 First Class Brickwork		5
3.4.2 Limitation		5
3.5 Mortar		5
4 General Construction and Design Requirements		7
4.1 General		7
4.2 Selection of Mortar		7
4.3 Thickness of Walls		7
4.4 Stability Requirements		8
4.4.1 Lateral Support		8
4.4.2 Adequate Lateral Support		8
4.5 Parapets and Compound Walls		9
4.5.1 General		9
4.5.2 Free-Standing Walls		9

	4.5.3	Load Bearing Masonry Elements.....	9
	4.5.4	Slenderness Ratio.....	9
	4.5.5	Curtain Walls.....	9
4.6		Structural Design	9
4.7		Design Method.....	10
	4.7.1	Design Procedures	10
	4.7.2	Design Loads	10
	4.7.3	Design of Wall Footings	10
		4.7.3.1 Depth of Footing.....	10
		4.7.3.2 Width of Footing	11
	4.7.4	Permissible Compressive Stresses.....	11
5		General Requirements	12
	5.1	Deforming and Cracking	12
	5.2	Cutting and Chasing.....	12
		5.2.1 Stretches of Masonry	12
		5.2.2 Horizontal Chases	12
		5.2.3 Vertical Chases	12
		5.2.4 Masonry Directly Above A Recess.....	12
	5.3	Workmanship	13
		5.3.1 Bedding of Masonry Units	13
		5.3.2 Bond	13
6		Special Considerations for Earthquake Resistance	13
	6.1	Siting	13
	6.2	General Concepts	13
		6.2.1 Categories of Buildings	13
		6.2.2 Seismic Zoning.....	14
		6.2.3 Importance of Building	14
7		Site Considerations	16
	7.1	General.....	16
	7.2	General Considerations.....	16
	7.3	Site Investigation Requirements	16
	7.4	Allowable Bearing Pressure.....	17
	7.5	Combination of Parameters.....	17
8		Openings in Walls	21

9	Masonry Bond	22
	9.1 Vertical Joints between Perpendicular Walls	22
10	Horizontal Reinforcement in Walls	23
	10.1 Horizontal Bands or Ring Beams	23
11	Section of Bands or Ring Beams	25
12	Dowels at Corners and Junctions	28
13	Vertical Reinforcement in Walls	31
14	Reinforcement Details for Hollow Block Masonry	33
	14.1 Horizontal Band	33
15	Vertical Reinforcement	34
	15.1 Infill Panels and Non Structural Walls	34
16	Wall Thickness and Spacing	36

0. Foreword

0.1 Design Aspect Covered

This Code of Practice covers the structural design aspect of unreinforced masonry elements in the buildings. It also deals with some aspect of earthquake-resistant design of buildings. References to seismic zoning, seismic coefficients, important factors, structural performance factors and performance coefficient are as per **NBC 105-94 Seismic Design of Buildings in Nepal**.

0.2 Related Codes

This Code should be read in conjunction with the Indian Standard **IS:1905-1987 Code of Practice for Structural Use of Unreinforced Masonry (Third Revision)**.

1 Scope

1.1 Coverage

This is a Code of Practice for the Structural Design Aspects of Unreinforced Masonry Buildings in Nepal.

1.2 Limitation

The recommendations of this Code of Practice do not cover walls constructed in mud mortar and should not be used for such case.

1.3 Provisions for Historical Buildings

The provisions of this Code of Practice shall be construed as advisory when being applied to the repair, alternations or additions necessary for the conservation, preservation, restoration, rehabilitation, reconstruction or continued use of buildings of historical, architectural, cultural or archaeological significance.

2 Interpretation

2.1 General

In this Code of Practice the word "shall" indicates a requirement that is to be adopted in order to comply with the Code of Practice, while the word "should" indicates recommended practice.

2.2 Terminology

BEDDED AREA means the area of surface of a masonry unit which is in contact with mortar in the plane of joint.

CORBEL means one or more courses of brick projecting from a wall (such as a cornice), generally to form a support for wall plates, etc. A brick should not project more than one quarter of its length beyond the next lower course.

DEFINITIONS : The terminology given in Indian Standard **IS:1905-1987** in clauses 2.1 to 2.21.3 will apply, except as stated here below.

DIMENSION means the measured dimension of a designed item and, if used to describe masonry units, means the nominal dimension.

INFILL PANEL means a wall framed on four sides by columns and beams and contributing to shear resistance in the plane of the frame, but which is not designed to resist vertical loads other than its own weight.

LATERAL SUPPORT means a masonry structure support which enables a masonry element to resist lateral load and/or restrains the deflection of the masonry element at the point of support.

MASONRY means an arrangement of masonry units which may be brick, rectangularised stone, ashlar or cement blocks laid to a bond and joined together with mortar.

MASONRY UNIT means an individual unit which is bonded to similar units with the help of mortar to form a masonry element such as a wall, column, pier, buttress, etc., and conforming to the Nepal Standard **Brick Masonry NS: 1/2035**.

PANEL WALL means an exterior non load-bearing wall in framed construction wholly supported by beams and columns.

PARTITION WALL means an interior non load-bearing wall which is separated so as not to be part of the seismic resisting structure.

PARTY WALL means a wall built on land belonging to two adjoining owners, it being the joint property of both the owners.

SLENDERNESS RATIO means the ratio of effective height or effective length to the effective thickness which ever is less.

$$\begin{aligned} \text{SR} &= \text{Slenderness Ratio} \\ &= \frac{\text{Effective Height}}{\text{Effective Thickness}} \text{ or } \frac{\text{Effective Length}}{\text{Effective Thickness}} \end{aligned}$$

2.3 Symbols

The following letters, symbols and abbreviation are used for the purposes of this section and other symbols are specified at their respective places.

<i>A</i>	Area of section
<i>b</i>	Breadth of masonry unit or shorter dimension of a rectangular column
<i>DL</i>	Dead load
<i>E</i>	Modulus of elasticity
<i>e</i>	Eccentricity
<i>f_b</i>	Basic compressive stress
<i>f_c</i>	Permissible compressive stress
<i>f_d</i>	Compressive stress due to dead load

f_s	Permissible shear stress
K	Stiffness of member
k_a	Area factor
k_p	Shape modification factor
k_s	Stress reduction factor
LL	Live load
l	Axial load on a compression member
l_{ef}	Effective length or span
m	Modular ratio
W	Total load
WL	Wind load
w	Uniform distributed load
w_p	Breadth of crosswall, piers, or buttresses
Z	Modulus of section

3 Materials

3.1 Permissible Material

The materials used in masonry construction shall be in accordance with **NBC 101-94 Material Specifications** unless otherwise specified.

3.2 Masonry Unit

The specification and properties of the masonry shall conform to the Nepal Standard **Brick Masonry NS: 1/2035**. Its size is given below :

Dimensions of Nepal Standard Brick (mm)				
Length	Breadth	Height	Vertical Mortar Joint	Remark
240	115	57	10	For 10 mm mortar joint

Table 3.1 : Dimensions of a Nepal Standard Brick

Note : Length of Brick = 2 x Width of Brick + 1 Vertical Mortar Joint

3.3 Tolerances

Tolerance for First and Second Class bricks are as in given **Tables 3.2. and 3.3**

Individual Brick Size (Nominal Dimensions) (mm)				Length of 20 Bricks (mm)	
Class	Length	Breadth	Height	Minimum	Maximum
A	240	-	-	4700	4860
A	-	115	-	2240	2360
A	-	-	57	1170	1270

Table 3.2 : Individual Brick Size And Length of 20 Bricks (Class A)

Individual Brick Size (Nominal Dimensions) (mm)				Length of 20 Bricks (mm)	
Class	Length	Breadth	Height	Minimum	Maximum
B	240	-	-	4660	4880
B	-	115	-	2200	2360
B	-	-	57	1150	1270

Table 3.3 : Individual Brick Size and Length of 20 Bricks (Class B)

3.4 Classification of Bricks and Brickwork

3.4.1 First Class Brickwork

All the bricks used for masonry construction shall be thoroughly burnt, deep cherry red or copper in colour, regular in standard shape and size, free from cracks, emit a clear ringing sound on tapping with a steel trowel and have a crushing strength as per the Nepal Standard **Brick Masonry NS: 1/2035**. A brick shall not absorb more water than 15 % of its weight after 24 hours of soaking in water at normal temperatures. However, hand-made bricks with keys may have water absorption up to 25 % of their weight. For first class brickwork, the corresponding mortar types should be H1 and H2.

3.4.2 Limitation

Masonry units that have been previously used should not be re-used in brick work or brickwork construction unless they have been thoroughly cleaned and shown to conform to the Nepal Standard **Brick Masonry NS: 1/2035**.

3.5 Mortar

Mortar used in masonry construction shall, unless otherwise specified, conform to the specification listed in **NBC 101 – Material Specifications**.

Some of the commonly-used mortars in Nepal and their mix proportions, along with their strengths, are listed in **Table 3.4**.

Serial No.	Mix (by volume)			Minimum Compressive Strength at 28 days (N/mm ²)*	Mortar Type
	Cement	Lime	Sand		
1	1	0 to 0.25 C	3	10.0	H1
2(a)	1	0	4	7.5	H2
2(b)	1	0.5 C	4.5	6.0	H2
3(a)	1	0	5	5.0	M1
3(b)	1	1 C	6	3.0	M1
4(a)	1	0	6	3.0	M2
4(b)	1	2 C	9	2.0	M2
4(c)	0	1 A	2 to 3	2.0	M2
5(a)	1	0	8	0.7	L1
5(b)	1	3 C	12	0.7	L1
6	0	1 B or C	2 to 3	0.5	L2

* 1 N/mm² = 1 MPa = 10.2 kg/cm²

Table 3.4 : Mix Proportions and Strength of Commonly- Used Mortars for Masonry

Notes :

- i) *The strength of mortar may vary appreciably depending on the angularity, grading and fineness of the sand. The quantity of sand in the mix may, therefore, be decreased where found necessary to attain the desired strength.*
- ii) *A, B and C denote eminently hydraulic lime, semi-hydraulic lime and fat lime respectively.*
- iii) *When using plain cement sand mortars [S. No. 2(a), 3(a), 4(a), and 5(a)], it is desirable to include a plasticizer in the mix to improve workability.*
- iv) *For mortar to S. No. 6, if lime C is used, part of the sand should be replaced by some pozzolanic materials (eg., burnt clay or fly ash), in order to obtain the required compressive stress.*
- v) *In this table, the classification of mortars as types H1, H2, M1, M2, L1 or L2 has been given for convenience of reference in design calculations, the letter H standing for high strength, M for medium strength and L for low strength.*
- vi) *For mortar types H2, M1, and M2, although the compressive strength of composite*

mortars (that is, cement and lime mortars) is somewhat less than that of cement mortars, the masonry strength may not be significantly affected.

4 General Construction and Design Requirements

4.1 General

The provisions in clause 4.1 to 4.7 of the Indian Standard **IS:1905-1987** shall be applicable for designing masonry structures. In addition, the following clauses will also be equally applicable :

4.2 Selection of Mortar

The requirements of a good mortar for masonry structure are workability, strength, water retentively and low drying shrinkage. Mortar strength in general should not be greater than that of the masonry unit. For commonly-used mortars conforming to **Table 3.4**, the optimum mortar mixes from a brick strength consideration are given in **Table 4.1**.

Masonry Unit Strength (N/mm ²)	Mortar Type
below 5	M2
5 to 14.9	M1
15 to 24.9	H2
25 or above	H1

Table 4.1 : Optimum Mortar Mixes For Maximum Masonry Strength with Masonry Units of Various Strengths

4.3 Thickness of Walls

- a) The thickness of a load-bearing wall shall be sufficient at all points to ensure that stresses due to the worst condition of loading for which the wall is designed are within the safe limit. The thickness of non load-bearing walls shall be sufficient to meet considerations of stability and strength against lateral forces.

- b) The thickness used for design calculation shall be the actual thickness of the masonry, not the nominal thickness. The actual thickness shall be computed as the sum of the average dimensions of the masonry units as specified in the Nepal Standard **Brick Masonry NS:1/2035**, together with the specified joint thickness. In masonry with raked joints, the thickness shall be reduced by the depth of raking. However, if joints are raked to provide a key for subsequent plastering and the mix of mortar for plastering is not weaker than the masonry mortar, raking may be ignored. Also, if the raking of joints is to be followed by flush-pointing using a mortar of the same or better strength, the raking may be ignored.
- c) The thickness of a wall determined from strength considerations may not be always sufficient to satisfy requirements with regard to other properties of the wall such as resistance to fire, thermal insulation, sound insulation or resistance to rain penetration.

4.4 Stability Requirements

4.4.1 Lateral Support

Lateral support for a masonry element such as a wall or column is required:

- a) to resist horizontal components of the forces so as to ensure stability of the structure against over-turning; and
- b) to limit the slenderness of masonry elements in order to prevent failure by buckling.

4.4.2 Adequate Lateral Support

A wall or column may be considered to be provided with adequate lateral support if the construction providing the support is capable of resisting the greater of the following lateral forces :

- a) The simple static reactions at the point of lateral support to the total applied horizontal forces ; or 2.5 percent of the total vertical load that the wall or column is designed to carry at the point of lateral support.

Lateral support may be provided in either the vertical or horizontal direction. Horizontal lateral support could consist of the floor/roof acting as a horizontal girder capable of transmitting without excessive stresses the horizontal forces to cross-walls acting as stiffening walls. Vertical support could consist of cross-walls/piers/buttresses capable of transmitting without excessive stresses the horizontal forces to the foundation.

4.5 Parapets and Compound Walls

4.5.1 General

Since, in the case of a free-standing wall such as a compound wall or parapet wall, there is no lateral support at its top and no cross-walls to brace the same, stability shall be achieved by designing the wall as a gravity structure such that the factor of safety against overturning is at least 1.5. As straight walls designed on this basis tend to be heavy, the stability of free-standing walls greater than 0.9 m in height should be achieved by staggering or by the provision of piers or buttresses. Even though a straight free-standing wall may be stable with the stipulated factor of safety (1.5), it will have some tension, because a condition of zero tension corresponds to a factor of safety of 3 against overturning. Mortar used in masonry of a straight, free-standing wall should not normally be weaker than type M1 indicated in **Table 4.1** unless walls are thick enough in relation to their height so as to be free from any tension.

4.5.2 Free-Standing Walls

A free-standing wall must be designed to be safe as a vertical cantilever. All partition walls inside a building must be held on their sides as well as at their tops.

4.5.3 Load Bearing Masonry Elements

In the case of an unreinforced load-bearing wall using ordinary Portland cement, the slenderness ratio shall not exceed 17.

4.5.4 Slenderness Ratio

The slenderness ratio for a load-bearing column shall not exceed 12.

4.5.5 Curtain Walls

Curtain walls shall be designed as panel walls to resist lateral forces caused by wind or earthquakes in addition to their own weight. The junction details at the lateral supports shall be such that any vertical deformations or rotations of the structural members providing the lateral support are not transferred to the curtain wall. Similarly, there shall be freedom for the curtain wall to have deformation in the vertical direction.

4.6 Structural Design

The specification laid down in clauses 5.1 to 5.5.5 of Indian Standard **IS:1905-1987** shall apply to the structural design of masonry. The additional clauses as given here under shall also apply.

4.7 Design Method

The structural design of non-reinforced masonry shall be as per the design procedures given below :

4.7.1 Design Procedures

The building as a whole shall be analysed by accepted principle of mechanics to ensure the safe and proper functioning in service of its component parts relative to the whole building. All component parts of the structure shall be capable of sustaining the most adverse combinations of loads to which the building may be reasonably expected to be subjected during or after erection.

4.7.2 Design Loads

Loads to be taken into consideration for designing masonry components of a structure are :

- a) dead load of walls, column, floors and roofs;
- b) live load on floors and roof;
- c) wind load on walls and roof; and
- d) seismic forces.

4.7.3 Design of Wall Footings

4.7.3.1 Depth of Footing

The net safe bearing capacity of the soil and the depth of foundation in the soil are best determined by modern soil investigation methods. In the absence of such an investigation report, a conservative minimum depth of footing may be determined using the following formula :

$$D = \frac{P}{W} \left(\frac{1 - \sin\lambda}{1 + \sin\lambda} \right)^2$$

where :

D = minimum depth of footing in metres.

P = net safe bearing capacity of soil (kPa).

W = unit weight of soil (kN/m³).

λ = angle of repose of soil in degrees.

Note : The above formula is not valid if the soil condition is Soft or Weak as categorised in **Table 7.1**. In all

cases, the footing should be founded below seasonal moisture variation and to consistent bearing

4.7.3.2 Width of Footing

The minimum width of the footing, B , shall be obtained by dividing the total load (including dead loads), live and wind load) by the allowable bearing capacity of the soil :

$$B = \frac{T}{P}$$

where :

B = width of footing in metres.

T = total load per metre.

P = safe bearing capacity.

Note : The above formula is not valid if the soil condition is Soft or Weak as categorised in **Table 7.1**.

4.7.4 Permissible Compressive Stresses

The permissible compressive stresses shall be in accordance with the Indian Standard **IS : 1905-1987** in which the design value of permissible compressive stress, f_c , depends on a combination of the following factors :

- 1) basic compressive stress based on type and strength of the masonry units and mix of mortar, f_b
- 2) factor for slenderness ratio and eccentricity of masonry elements, k_{se}
- 3) factor for shape and size of the masonry unit, k_p
- 4) factor for cross-sectional area of masonry, k_a and
- 5) factor for load type, k_l

so that :

$$f_c = f_b k_{se} k_p k_a k_l$$

The values of the basic compressive stresses and the various factors are given in **IS : 1905-1987**, clause 5 and its subclauses.

5 General Requirements

5.1 Deforming and Cracking

Special provisions shall be made to control or isolate thermal and other movements so that damage to the fabric of the building is avoided and its structural sufficiency is preserved. The design and installation of joints shall be done in accordance with accepted practice.

5.2 Cutting and Chasing

As far as possible, service (Electrical, Plumbing, etc.) should be planned with the help of vertical chases. Horizontal chases should be avoided.

For load-bearing walls, the depth of vertical chases and horizontal chases shall not exceed one-third and one-sixth of the thickness of the masonry, respectively.

No chase shall be permitted in a half-brick load-bearing wall.

5.2.1 Stretches of Masonry

When narrow stretches of masonry (or short lengths of wall), such as between doors and windows, cannot be avoided, they should not be pierced with openings for soil pipes or waste pipes or timber joists, etc. Where there is a possibility of load concentration, such narrow lengths of walls shall be checked for stresses and high-strength bricks/mortar or concrete walls provided, if required.

5.2.2 Horizontal Chases

Horizontal chases, when unavoidable, shall be located in the upper or lower thirds of a storey and not more than three chases should be permitted in any stretch of a wall. No continuous horizontal chase shall exceed one metre in length.

5.2.3 Vertical Chases

Vertical chases shall not be closer than two metres in any stretch of a wall. These shall be kept away from the bearing of beams and lintels. If unavoidable, stresses in the affected area should be checked and kept within permissible limits.

5.2.4 Masonry Directly Above A Recess

Masonry directly above a recess, if wider than 30 cm (horizontal dimension), should be supported on lintel. Holes in masonry up to 30 cm width x 30 cm high may be provided without a lintel. In the case of circular holes in masonry, a lintel should be provided only if arch action can not be achieved.

5.3 Workmanship

The quality of workmanship has considerable effect on the strength of masonry and bad workmanship may reduce the strength of brick masonry to as low as half the intended strength. The basic compressive stress values for masonry given in **IS : 1905-1987, Table 8** are appropriate for commercially-obtainable standards of workmanship with a reasonable degree of supervision. If the work is going to be inadequately supervised, design strengths should be reduced to three-quarters of these values.

5.3.1 Bedding of Masonry Units

Masonry units shall be laid on a full bed of mortar with the frog, if any, upward and so that cross-joints and bed-joints are completely filled with mortar. Masonry units which are moved after their initial placement shall be re-laid in fresh mortar. Old or disturbed mortar shall be discarded.

5.3.2 Bond

The cross-joints in any course of one brick thick masonry walls shall be not less than one quarter of a masonry unit in horizontal measurement from the cross-joints in the course below. In masonry walls more than one brick in thickness, bonding through the thickness of the wall shall be provided by either header units or by other equivalent means.

6 Special Considerations for Earthquake Resistance

6.1 Siting

The site should be free from landslide and rock fall areas and liquefaction potential (loose, saturated sand up to about six metres depth below the ground surface). See **NBC 108-94 Site Considerations** for more details.

6.2 General Concepts

6.2.1 Categories of Buildings

For categorizing buildings for the purpose of achieving seismic resistance at economical cost, three parameters turn out to be significant :

- a) Seismic Intensity Zoning where the building is located,
- b) Important of the building and
- c) Stiffness of the foundation soil.

A combination of these parameters will determine the extent of appropriate seismic strengthening of the building.

6.2.2 Seismic Zoning

The variation in seismic hazard with location in Nepal is defined for design purposes in Figure 8.2 of **NBC105-94 Seismic Design of Buildings in Nepal**. For the purpose of the design of unreinforced masonry, a simplified zonation based on this figure shall be used.

Three zones A, B and C are defined in **Table 6.1** and are shown in **Figure 6.1** below.

Zone	Zone Coefficient	Risk
A	$Z \geq 1.0$	Widespread Collapse and Heavy Damage
B	$0.8 \geq Z > 1.0$	Moderate Damage
C	$Z < 0.8$	Minor Damage

Table 6.1 : Seismic Zones for Unreinforced Masonry

6.2.3 Importance of Building

The importance of the building should be a factor in grading it for strengthening purposes. Importance depends upon its occupancy, use and need before and after a disaster as given in **Table 6.2**.

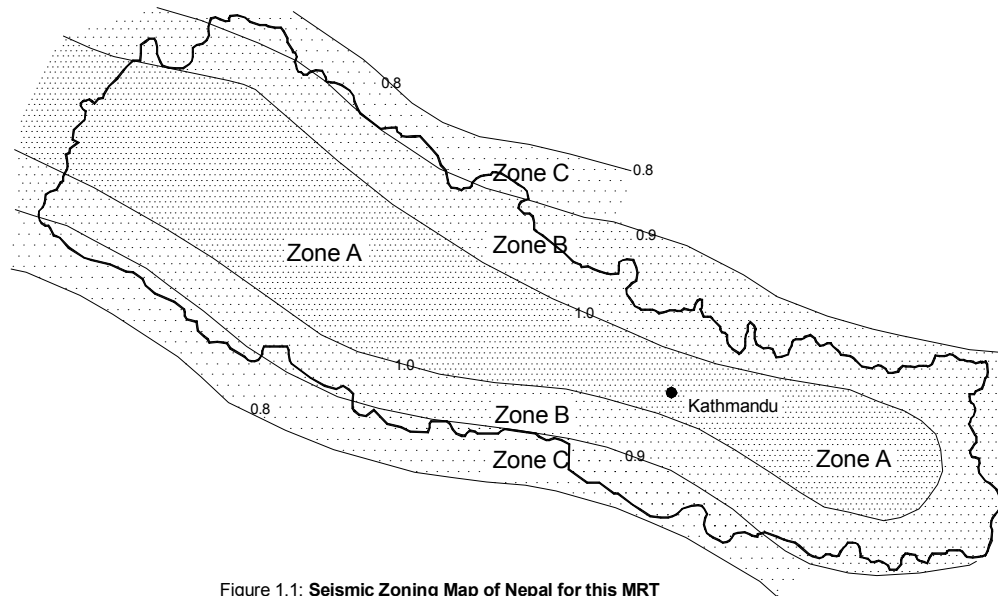

Figure 1.1: Seismic Zoning Map of Nepal for this MRT

Occupancy Category	Occupancy Type or Function of Structure
<p>IMPORTANT CATEGORY</p> <p>1. Essential Facilities</p>	<p>Hospital and other medical facilities</p> <p>Fire and Police Station</p> <p>Tanks or other structures containing, housing or supporting water or other fire-suppression material or equipment required for the protection of essential or hazardous facilities.</p> <p>Emergency vehicle shelter and garage</p> <p>Structures and equipment in emergency-preparedness centres and relief stores.</p> <p>Power stations and standby power-generating equipment for essential facilities</p> <p>Structures and equipment in communication centres eg. radio, television facility, telephone exchange etc.</p> <p>Food storage structures</p> <p>Offices and quarters for personnel related to central and district level rescue and relief operations eg. ministers, secretaries, police and army chiefs, CDO, LDO, DDC chairman, district level army and police chiefs</p>
<p>2. Places of Assembly</p>	<p>Schools, colleges, hostels cinema hall, culture, covered hall convention halls, temples, dharmashalas</p>
<p>3. Monumental Buildings</p>	<p>Historic buildings, palaces</p>
<p>4. Distribution Facilities</p>	<p>Gas or petroleum products in urban areas</p>
<p>5. Hazardous Facilities</p>	<p>Structures housing, supporting or containing sufficient quantities of toxic or explosive substances to be dangerous to the safety of the general public if release</p>
<p>ORDINARY CATEGORY</p> <p>6. Ordinary Occupancy Structures</p>	<p>Any structure / building not described above eg residential, offices, etc.</p>

Table 6.2 : Occupancy Category

The buildings under the Important category have been subdivided into two groups from a constructions point of view. These are :

- A. Buildings in accessible areas where modern materials such as cement and reinforcing bars can be easily transported
- B. Buildings in remote inaccessible areas to where modern materials can not easily be transported.

7 Site Considerations

7.1 General

This section sets out some of the requirements to be considered during site selection for the construction of buildings in order to minimise the risks to buildings from both primary geological hazards and secondary seismic hazards such as fault rupture, landslide and liquefaction. Since this is the first such effort to introduce the importance of geotechnical conditions and the nature of foundation soil in the stability of Nepalese building, the requirements set out here have deliberately been kept low to encourage effective implementation.

7.2 General Considerations

As a good practice during the construction of a building, it is necessary to examine all existing local knowledge and the performance histories of existing building. The designer should thus be able to identify any dangers from an inherent natural susceptibility of the land to the processes of sliding, erosion, land subsidence and liquefaction during past earthquakes, or from any other natural/geological process likely to threaten the integrity of the building. The local practice of managing such hazards, if any, should be judged against the required level of acceptable risk.

7.3 Site Investigation Requirements

For load-bearing masonry buildings and reinforced concrete (RC) frame buildings with masonry infills, site exploration should be carried out by digging test pits, two as a minimum, and more if the subsurface soil conditions show a variation in soil types.

Generally the depth of exploration for the buildings should be a minimum of two metres. In hilly areas, exploration up to the depth of sound bed rock, if it lies shallower than two metres, should suffice.

No exploration shall be required if the site is located on rock or on fluvial terraces (Tar) with boulder beds.

The soils encountered in the test pits should be classified as per **Table 7.1**.

7.4 Allowable Bearing Pressure

The allowable bearing pressure could be calculated using the **Table 7.1** in conjunction with the visual classification of the subsurface soil type.

Type of Soil/Rock	Foundation Classification	Presumed Safe Bearing Capacity (kN/m ²)
Rocks in different state of weathering; boulder beds; gravel; sandy gravel and sand-gravel mixtures; dense or loose coarse to medium sand; offering high resistance to penetration when excavated by tools; stiff to medium clay which is readily indented with a thumb nail.	Hard	≥ 200
Fine sand and silt (dry lumps easily pulverised by the finger); moist clay and sand-clay mixtures which can be indented with strong thumb pressure.	Medium	≥ 150 and < 200
Fine sand; loose and dry; soft clay indented with moderate thumb pressure.	Soft	≥ 100 and < 150
Very soft clay which can be penetrated several centimetres with the thumb; wet clays.	Weak	≥ 50

Table 7.1 : Classification of Foundaton Soil And Safe Bearing Capacity

Buildings can be constructed on hard, medium and soft soils but it will be dangerous to build them on weak soils. Hence, appropriate soil investigation should be carried out to establish the allowable bearing capacity and nature of soils. Weak soils must be avoided or compacted to improve them so that they qualify as at least Medium or Soft soils.

7.5 Combination of Parameters

For determining the categories of building for seismic strengthening purposes four categories (I to IV) are defined in **Table 7.2** in which category I will require maximum strengthening and category IV the least. The general planning and designing principles are, however, equally applicable to all categories.

Category	Combination of Conditions for the Category
I	Important Building on Soft Soil in Zone A
II	Important Building on Firm Soil in Zone A Important Building on Soft Soil in Zone B Ordinary Building on Firm Soil in Zone A
III	Important Building on Firm Soil in Zone B Important Building on Soft Soil in Zone C Ordinary Building on Firm Soil in Zone A Ordinary Building on Soft Soil in Zone B
IV	Important Building on Firm Soil in Zone C Ordinary Building on Firm Soil in Zone B Ordinary Building on Firm Soil in Zone C Ordinary Building on Soft Soil in Zone C

Table 7.2 : Categories of Buildings for Strengthening Purposes

Notes :

- i) Seismic Zones A, B and C are as per Figure 6.1*
- ii) Weak soils liable to compaction and liquefaction under earthquake conditions are not covered here.*

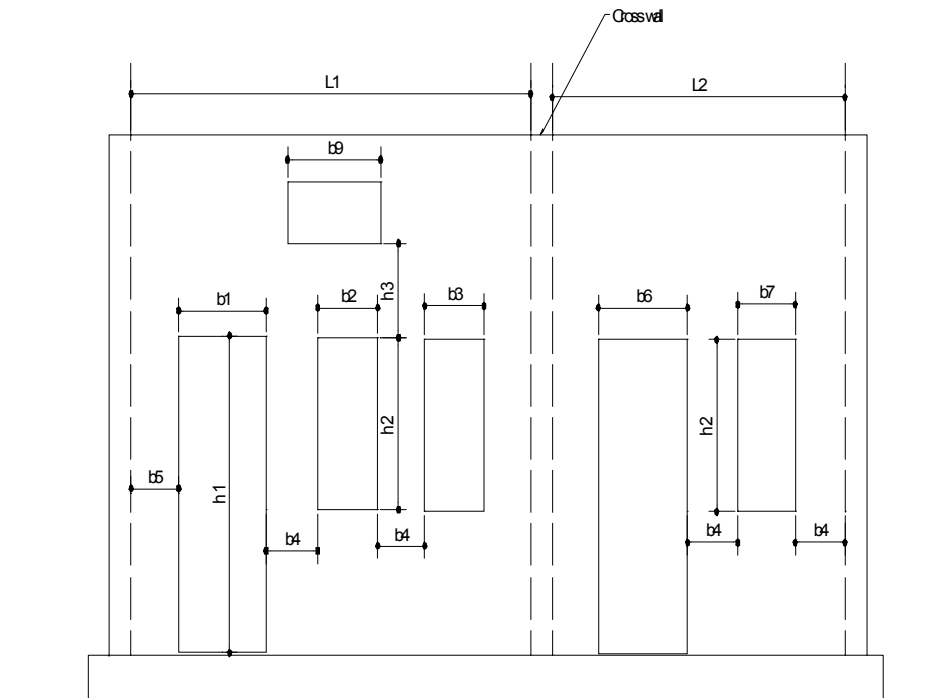

Note:

- i) $b_1 + b_2 + b_3$ $< 0.5 L_1$ for one storey, $< 0.42 L_1$ for two-storeyed, $< 0.33 L_1$ for three-storeyed
- ii) $b_6 + b_7$ $< 0.5 L_1$ for one storey, $< 0.42 L_1$ for two-storeyed, $< 0.33 L_1$ for three-storeyed
- iii) b_4 $> 0.5 h$, but not less than 600 mm
- iv) b_5 $> 0.25 h$, but not less than 600 mm
- v) b_3 > 600 mm and > 0.5 (bigger of b_2 and b_9)

Figure 7.1 : Recommendations Regarding Openings in Bearing Walls

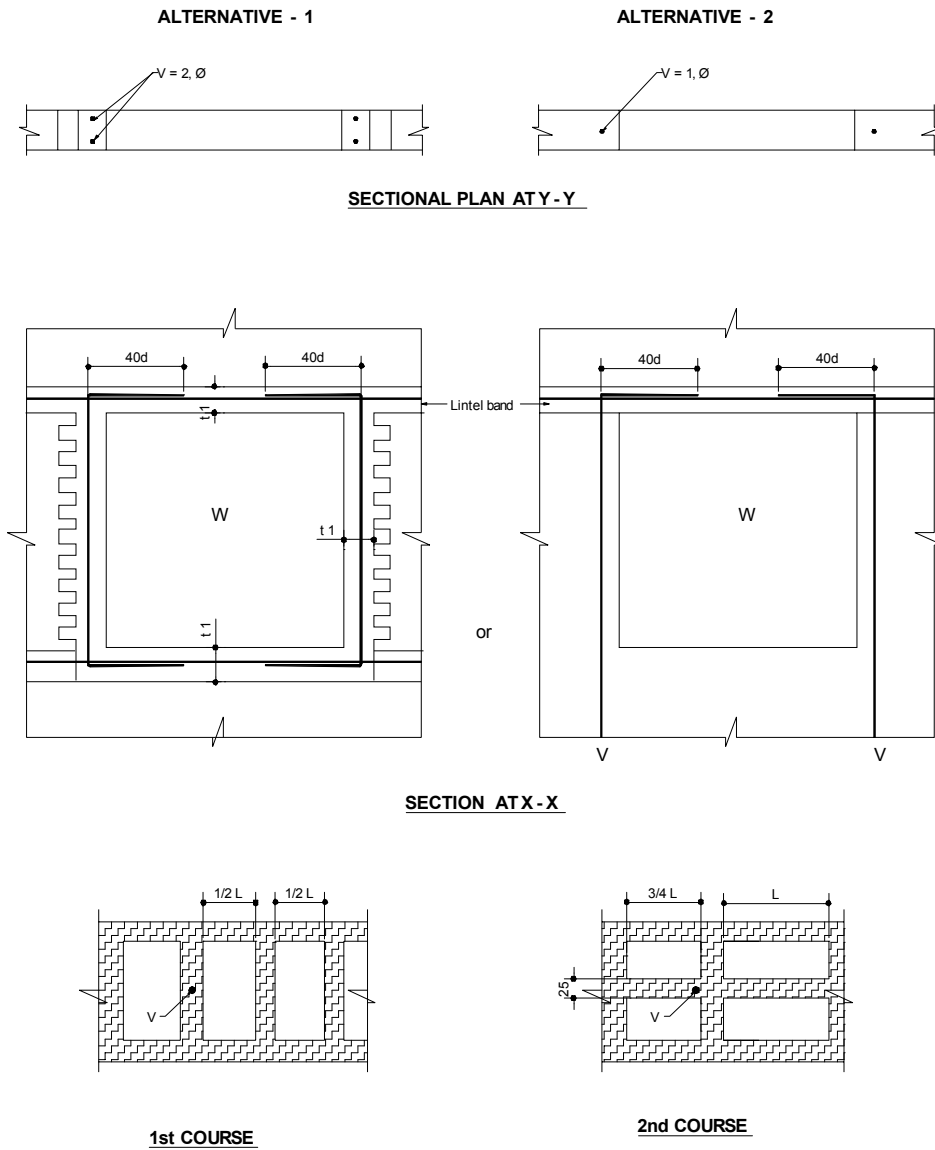

\varnothing -- Diameter, W -- Window, V --- Vertical Reinforcing bar,
 t -- Thickness of wall (minimum 1 brick length) ,
 t1 -- Minimum thickness 75 mm., L -- Length of brick unit.

Figure 7.2 : Strengthening of Masonry Around Openings

8 Openings in Walls

- a) Openings shall be located away from the inside corner by a clear distance equal to at least one-quarter of the height of openings, but not less than 600 mm.
- b) The total length of openings shall not exceed 50 % of the length of the wall between consecutive cross-walls in single-storey construction, 42 % in two-storey construction and 33 % in three-storey buildings.
- c) The horizontal distance (pier width) between two openings shall not be less than one-half of the height of the shorter opening (**Figure 7.1**), but not less than 600 mm.
- d) The vertical distance from an opening to an opening directly above it shall not be less than 600 mm, nor less than one-half of the width of the smaller opening (**Figure 7.1**)
- e) When openings do not comply with requirements (a) to (b), they should be boxed in reinforced jambs through the masonry (**Figure 7.2**)
- f) Tops of openings in a storey should preferably be at the same level, so that a continuous band which includes the lintels throughout the building can be provided.
- g) If a window or ventilator is to be projected out, the projection shall be in reinforced masonry or concrete and well-anchored.
- h) If an opening is tall enough with respect to the full height of wall so as to divide effectively the wall into two portions, these portions shall be reinforced with at least 6 mm diameter horizontal bars at not more than 600 mm intervals on both the inner and outer faces. This steel at jambs and at corners or junctions of walls.
- i) The use of arches to span over the openings is a source of weakness and shall be avoided unless steel ties are provided.
- j) All the walls must be effectively tied together to avoid separation at vertical joints due to ground-shaking during an earthquake.

9 Masonry Bond

9.1 Vertical Joints between Perpendicular Walls

A sloped or stepped joint should be made in order to obtain full bond by making the corners first to a height of 600 mm and then building the wall in between them. Alternatively, a toothed joint should be made in each wall alternately in lifts of about 450 mm, as shown in **Figure 9.1**.

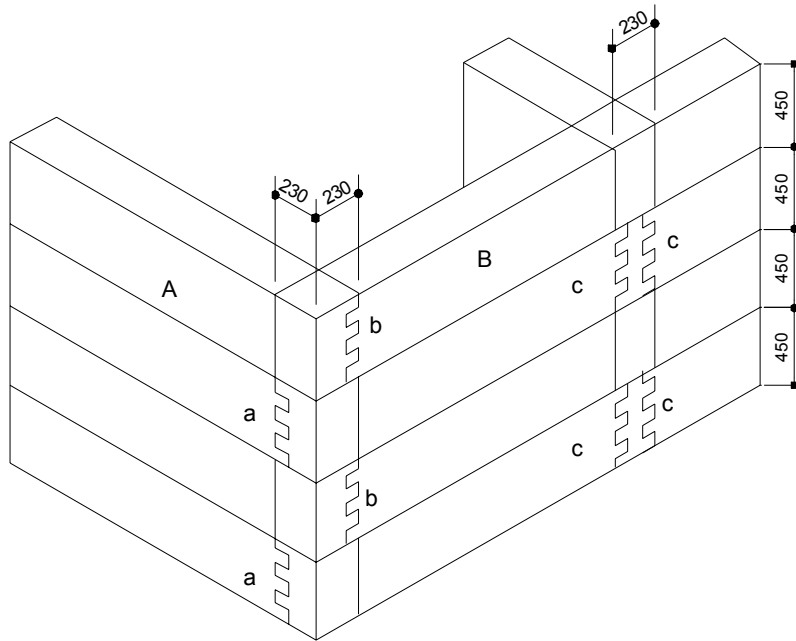

All dimensions are in mm.

a, b, c Toothed joint in walls A, B and C

(Alternating toothed joint in walls at corner and T-junctions)

Figure 9.1: A Typical Detail of Jointing in Masonry

10 Horizontal Reinforcement in Walls

Horizontal reinforcing of walls is required to give to them horizontal bending strength against plate-action for out-of-plane inertia loads, and for tying orthogonal walls together.

10.1 Horizontal Bands or Ring Beams

a) **Plinth Band**

A plinth band should be provided in all cases where the soil is soft or uneven in its properties.

b) **Lintel Band**

The lintel band shall incorporate all door and window lintels, the reinforcement of which should be extra to the lintel band steel. It must be provided in all storeys in all walls of the buildings as per **Table 11.1**.

c) **Roof Band**

A roof band shall be provided at the eave-level of trussed roofs (**Figure 4**), and also below or in the level of such floors that consist of joists and covering elements so as to properly integrate them at their ends and fix them into the walls.

d) **Gable Band**

Masonry gable-ends must have the triangular portion of masonry enclosed in a band, the horizontal part of which will be continuous with the eave-level band on longitudinal walls (**Figure 10.1**).

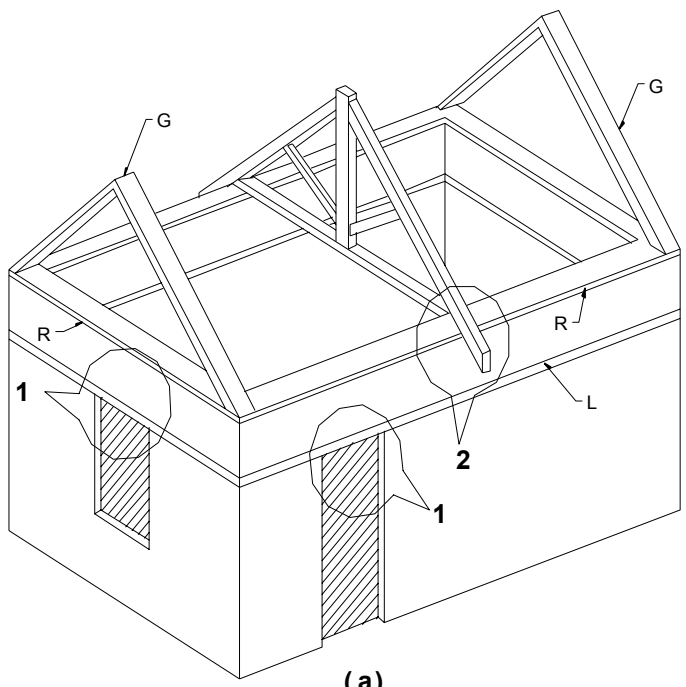

(a)

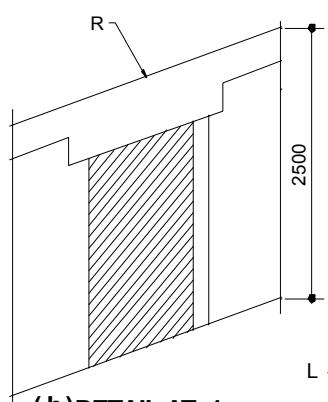

(b) DETAIL AT-1

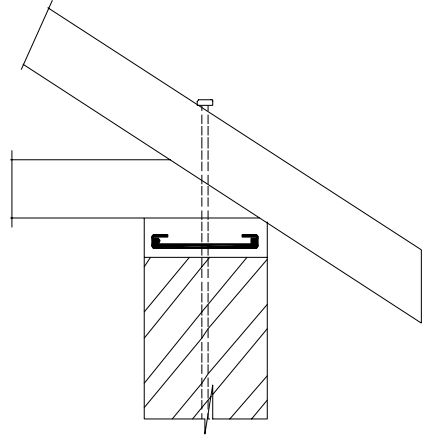

(c) DETAIL AT-2
(Fixing of roof to wall)

- L - Lintel band,
- R - Roof band
- G - Gable band

Note:

- i) As an alternative to the gable masonry, a truss or open gable may be used and the openings covered with a light material such as sheeting, matting etc.
- ii) If the wall-height up to eave-level is less than or equal to 2.5 m, the lintel band may be omitted and the lintel integrated with the eave-level band as shown in Detail 2.

Figure 10.1: Gable Band and Roof Band in Barrack-Type Buildings

11 Section of Bands or Ring Beams

A band consists of two (or four) longitudinal steel bars with stirrups embedded in 75 mm (or 150mm mm) thick concrete (**Figure 11.1 and 11.2**).

The thickness of the band may be made equal to, or a multiple of, a masonry unit, and its width shall equal the thickness of the wall.

The steel bars shall be located close to the wall faces with 25 mm cover, and full continuity shall be provided at corners and junctions.

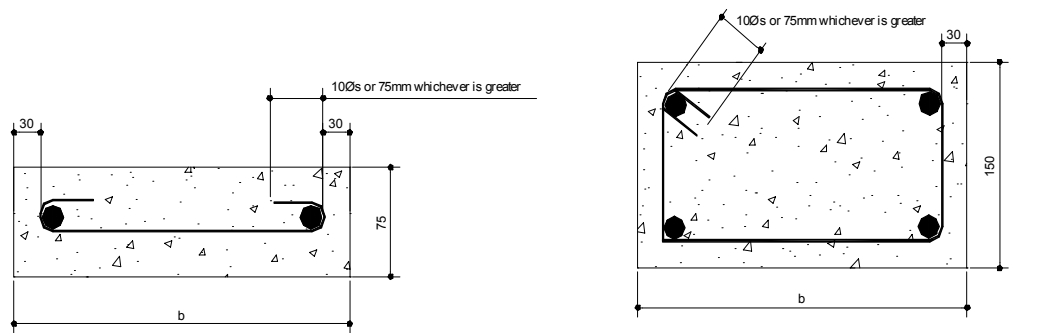

a) CROSS SECTION OF R.C. BAND FOR TWO BARS AND FOUR BARS OF DIA. ' \emptyset '

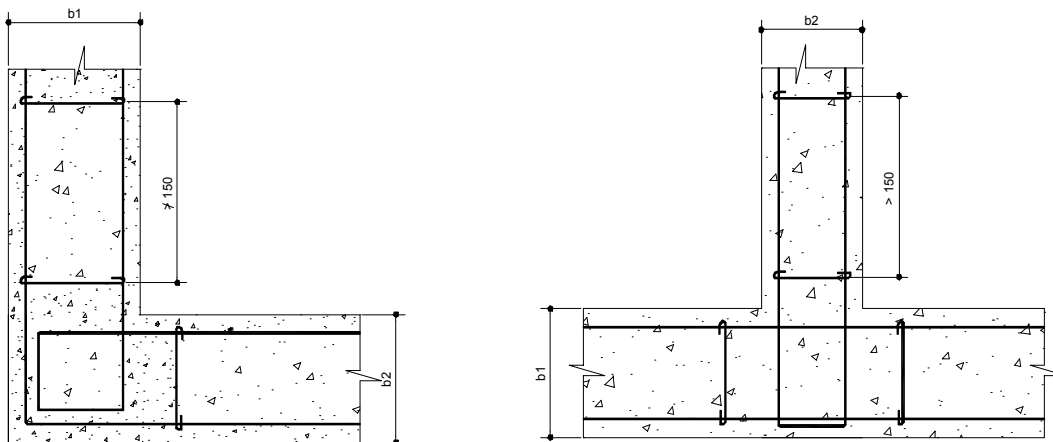

b) R. C. BAND REINFORCEMENT DETAILS AT CORNER AND T-JUNCTION

b, b1, b2 = Wall thickness
Concrete 1 : 2 : 4 or 15 N/mm² ϕ be strength.

Note:
Provide overlaps for slicing bars outside the corner length of overlap to develop full band say 50 d.

Figure 11.1: Reinforced Concrete Band and Details

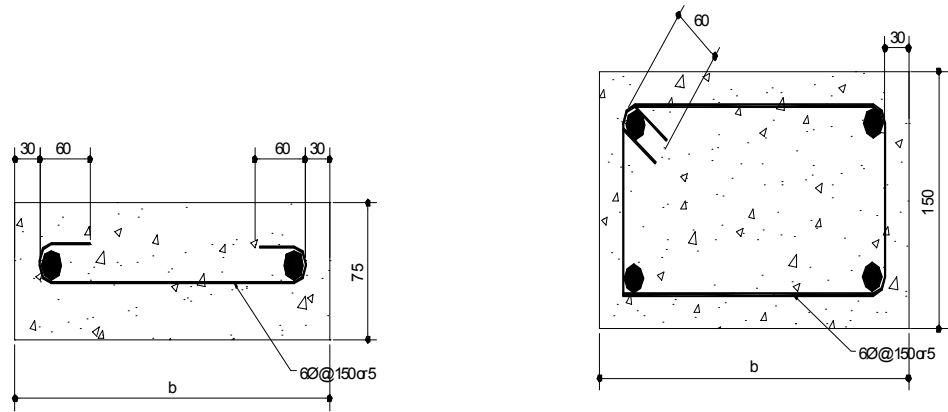

a) CROSS SECTION OF R.C.C. BAND FOR TWO BARS AND FOUR BARS

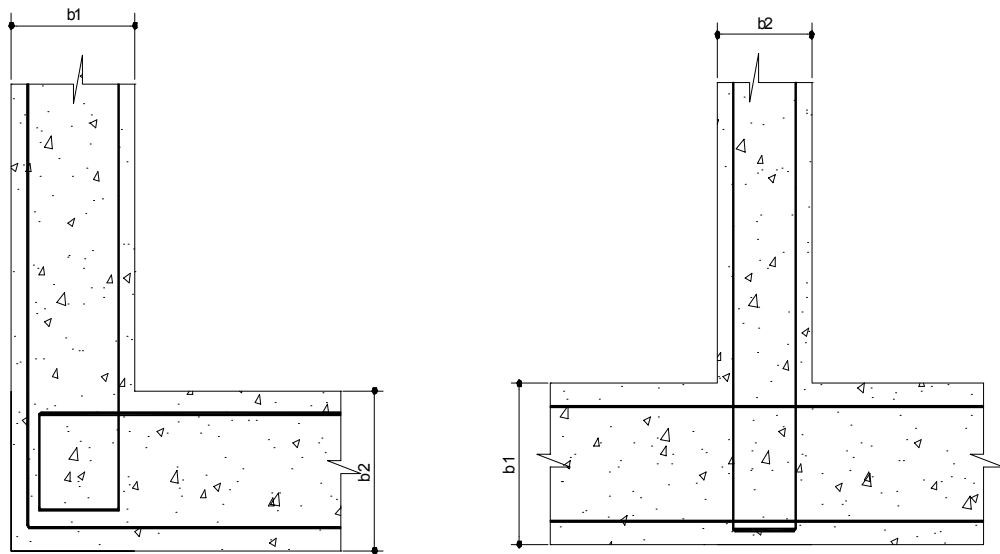

b) R. C. BAND REINFORCEMENT DETAILS AT CORNER AND T-JUNCTION

b, b1, b2 = Wall thickness
 Concrete 1:2:4 or 15 N/mm² strength

Note:

Provide overlaps for slicing bars outside the corner length of overlap to develop full band say 50d

Figure 112: Reinforcement in Reinforced Concrete Band

Longitudinal steel in Reinforced Concrete (RC) Bands												
Span of wall between cross wall (m)	Category I			Category II			Category III			Category IV		
	No. of Bars	Bar Dia. (mm)		No. of Bars	Bar Dia. (mm)		No. of Bars	Bar Dia. (mm)		No. of Bars	Bar Dia. (mm)	
		T*	K*		T	K		T	K		T	K
5 or Less	2	10	9	2	10	9	2	10	9	2	10	9
6	2	12	-	2	10	9	2	10	9	2	10	9
7	2	12	-	2	12	-	2	10	9	2	10	9

* T = High strength bar having an f_y of 415 N/mm² (Fe 415 Grade)

K = High strength bar having an f_y of 550 N/mm² (Fe 550 Grade)

Table 11.1 : Recommendation for Steel in RC Bands

Notes :

- i) *Width of the RC band is assumed to be the same as the thickness of wall. Wall thickness shall be 230 mm minimum. A cover of 25 mm from face of wall shall be maintained.*
- ii) *The vertical thickness of a RC band may be kept to a minimum of 75 mm where two longitudinal bars are specified and 150 mm where four longitudinal bars are specified.*
- iii) *Concrete mix to be 1:2:4 by volume or to have an M15 Grade cube crushing strength at 28 days.*
- iv) *The longitudinal bars shall be held in position by steel stirrups 6 mm in diameter spaced no more than 150 mm apart.*

12 Dowels at Corners and Junctions

Steel dowel bars shall be used at corners and T-junctions to integrate the box action of walls. Dowels (**Figures 12.1, 12.2, 12.3 and 12.4**) are to be taken into the walls to a sufficient length so as to provide their full bond strength.

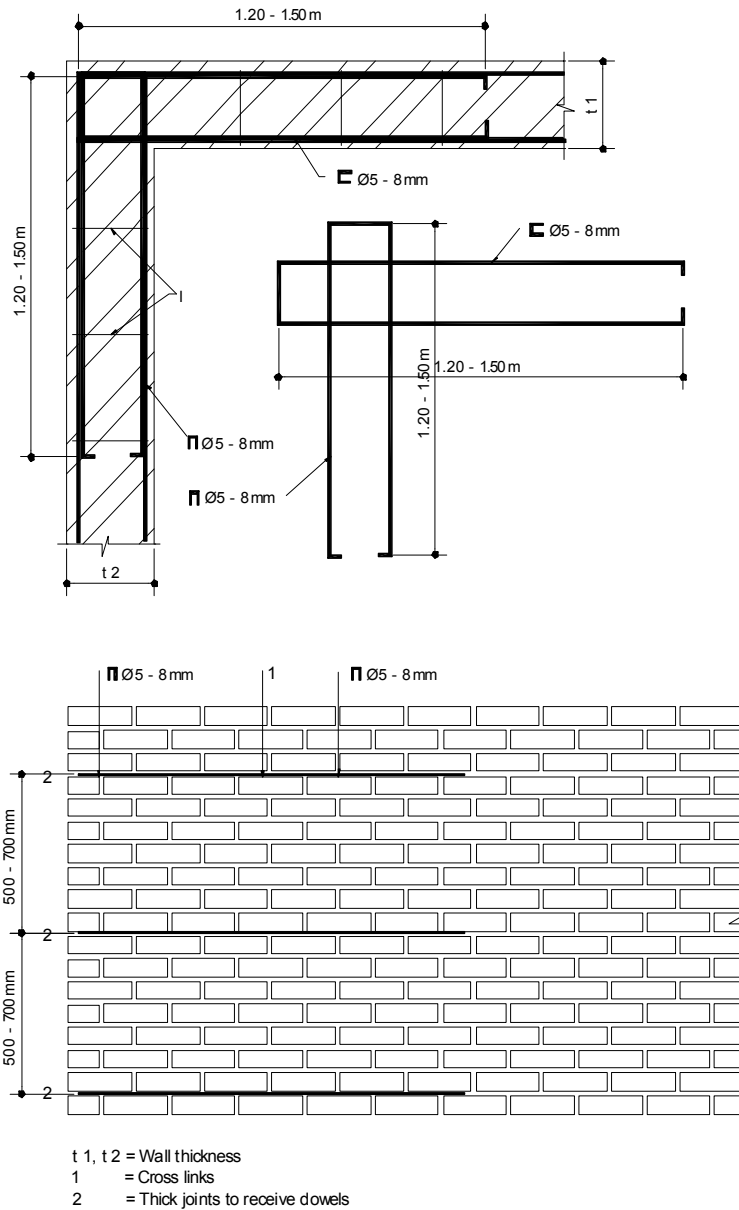

Figure 12.1 : **Corner-Strengthening by Dowel Reinforcement Placed in One Joint**

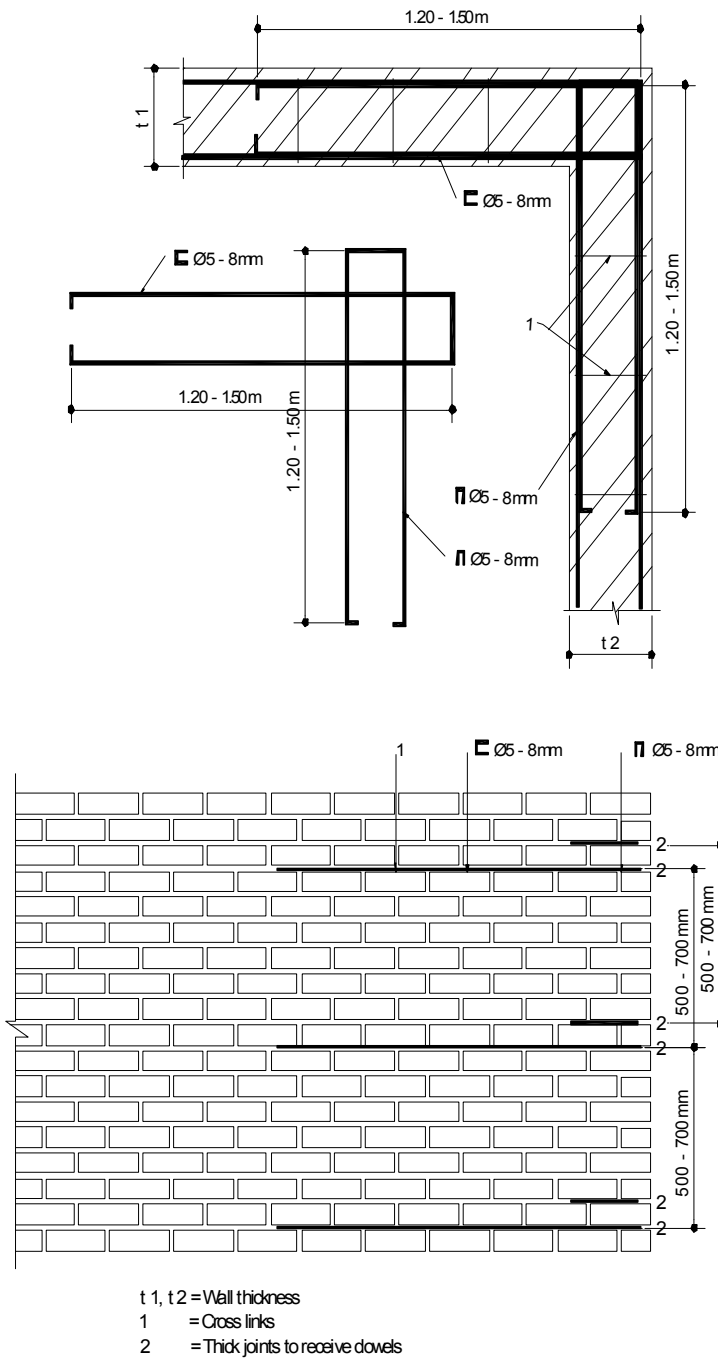

Figure 12.1: Corner-Strengthening by Dowel Reinforcement Placed in Two Consecutive Joint

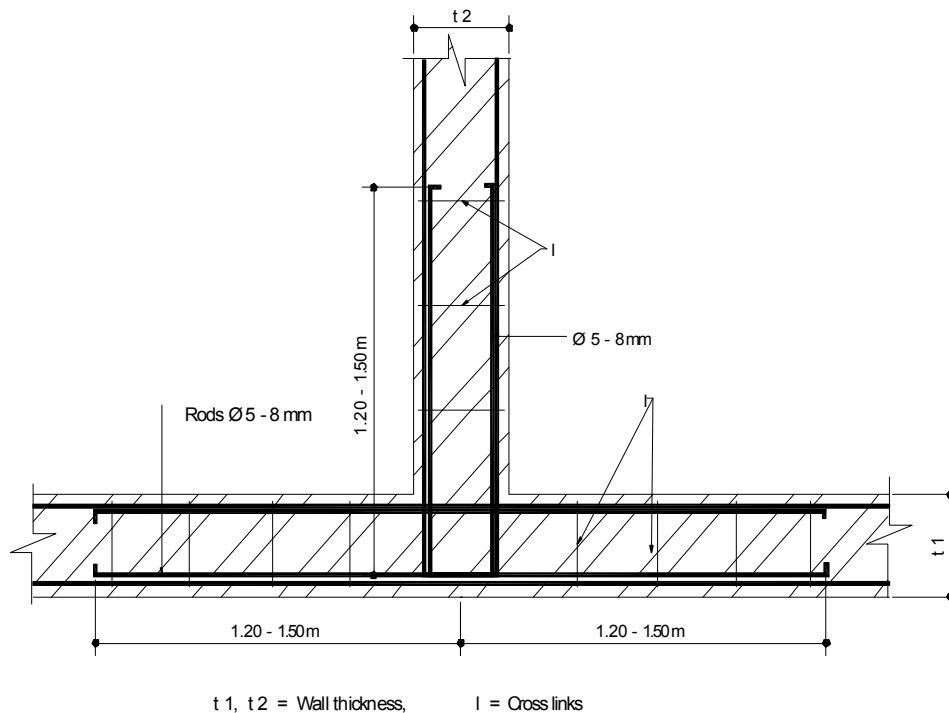

Figure 12.3: T-Junction Strengthening by Dowel Reinforcement

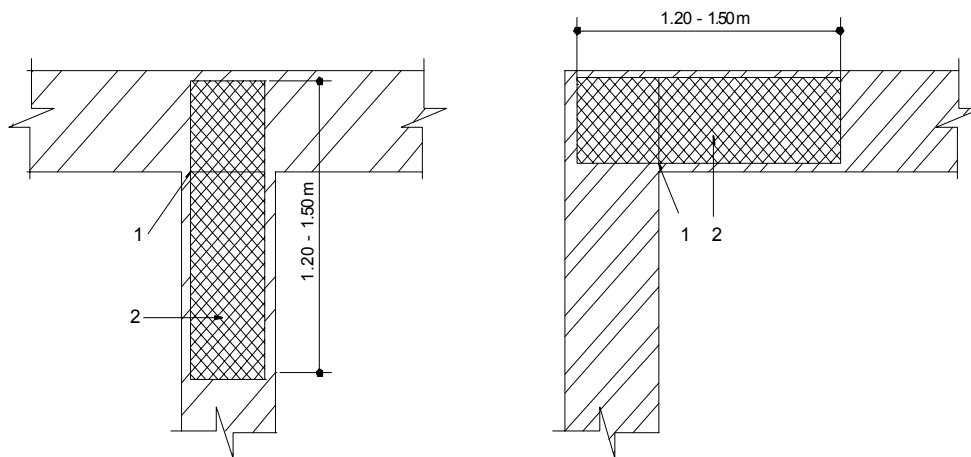

Figure 12.4: Strengthening by Wire Fabric at Junctions and Corners

13 Vertical Reinforcement in Walls

Steel bars shall be installed at the critical sections (i.e. the corners of walls and jambs of doors right from the foundation concrete) and covered with cement concrete in cavities made around them during masonry construction (**Figure 13.1**). This concrete mix should be 1:2:4 by volume or stronger.

The vertical steel at an opening may be stopped by bending it into the lintel band but the vertical steel at corners and junctions of walls must be taken into the floor slab, roof slab, or roof band.

Number of Storeys	Storey	Diameter of mild steel single bar in mm at each critical section by Category		
		Category I	Category II	Category III
One		12	10	10
Two	Top Bottom	12 16	10 12	10 12
Three	Top Middle Bottom	12 16 16	10 12 12	10 10 12

Table 13.1 : Recommendation for Vertical Steel at Critical Sections

Notes :

- i) *The above vertical reinforcement in walls is valid for up to three-storeyed buildings*
- ii) *Four-storeyed and above load-bearing wall construction may not be used for categories I and II buildings.*

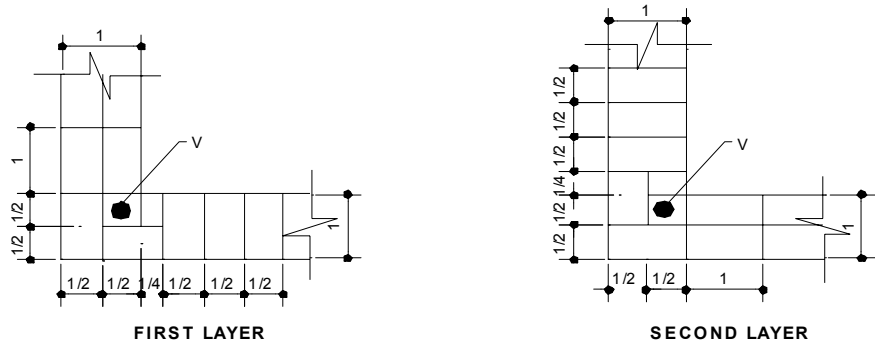

CORNER JUNCTION DETAILS FOR ONE BRICK WALL FOR PROVIDING VERTICAL STEEL.

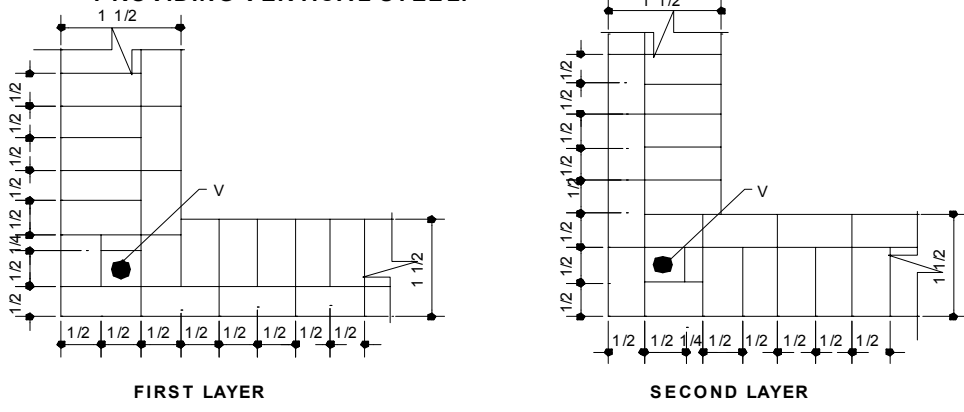

CORNER JUNCTION DETAILS FOR ONE AND HALF BRICK WALL FOR PROVIDING VERTICAL STEEL.

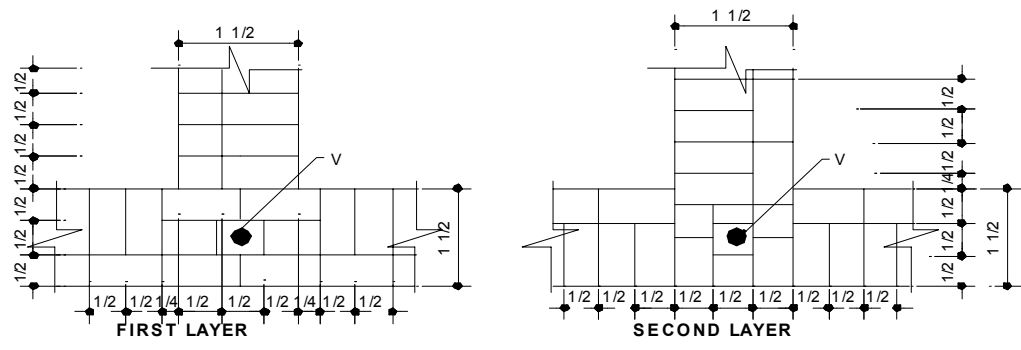

T- JUNCTION DETAILS FOR ONE AND HALF BRICK WALL FOR PROVIDING VERTICAL STEEL.

$\frac{1}{4}$, $\frac{1}{2}$, and 1 indicates: $\frac{1}{4}$ Brick wide, $\frac{1}{2}$ Brick wide, 1 Brick long etc.,
 V - Vertical Bar

Figure 13.1 : Vertical Reinforcement in Walls

14 Reinforcement Details for Hollow Block Masonry

14.1 Horizontal Band

U-shaped blocks should be used for the construction of horizontal bands at various levels of the storey as per seismic requirements as shown in **Figure 4.1**.

The amount of horizontal reinforcement shall be taken as 25 % more than that given in **Table 11.1** and provided by using four bars and 6 mm diameter stirrups.

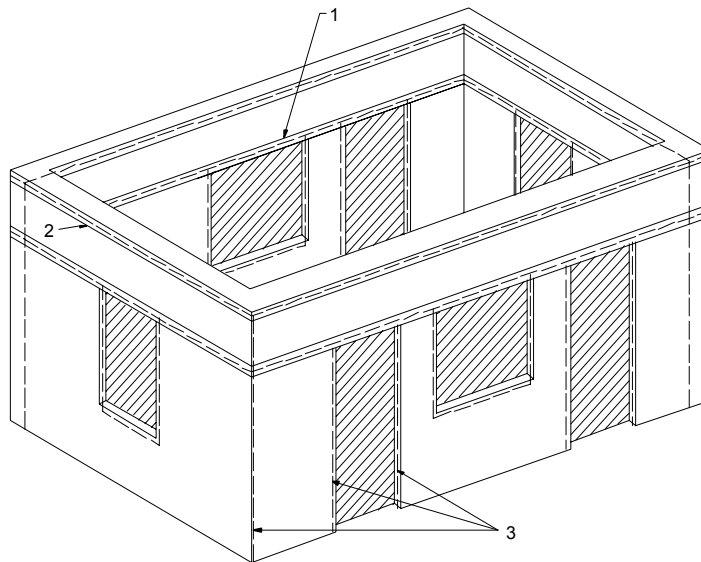

- 1 - Lintel Band
- 2 - Roof Band (only for pitched roofs and under roofs and floor)
- 3 - Vertical steel.

Figure 14.1: Overall Arrangement of Reinforcing Masonry Buildings

15 Vertical Reinforcement

The vertical bars specified in **Table 13.1** can be conveniently located inside the cavities of the hollow blocks - one bar in one cavity. Where more than one bar is planned, these can be located in two or three consecutive cavities as shown in **Figures 15.1 and 15.2**.

15.1 Infill Panels and Non-Structural Walls

- a) In-fill panel walls in a building shall be designed to ensure that they act together with the frame in full composite action.
- b) The seismic load at each level shall be distributed to the individual wall in proportion to the product of each wall's thickness and length. This product is representative of the diagonal strut area and thus of the wall's shear stiffness.
- c) Any frame is to be designed to resist all the gravity loads without any assistance from the infill walls as these walls may either fail or be very severely damaged in a large earthquake.
- d) The centre of rigidity of the infill walls (except face wall) shall be as near as possible to the centre of rigidity of the complete system of walls.
- e) An infill wall shall be so designed that it sustains minimum damage during any deflection of the supporting structure during an earthquake and shall be designed to resist all action resulting from in-plane and face loads.
- f) The minimum thickness of an infilled wall shall be the same as that of partition walls, and its openings should be as small as possible and cover not more than 10 % of the panel area. The preferable location of an opening in a wall is outside the central two-thirds of the sides and away from the corners. If the opening must be near the centre of the wall, it shall be bounded by a reinforced concrete beam 75 mm thick, the other dimension to be equal to thickness of wall and reinforced with two 10 mm diameter Fe 415 grade bars longitudinally and 5 mm diameter Fe 550 grade bar link ties .
- g) Partition walls shall have a minimum thickness shall have horizontal reinforcement (one 6 mm diameter bar in each face) in every sixth course of blockwork.
- h) If the infill wall is constructed in a Category I or II building, the thickness of infill wall shall not be less than 230 mm.

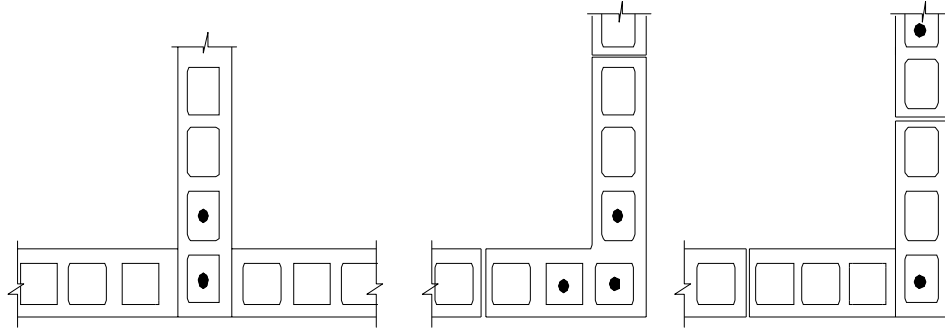

Figure 15.1: Vertical Reinforcement in Blockwork Cavities

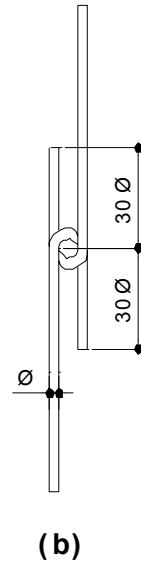
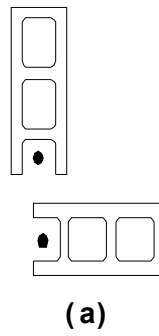

Figure 15.2: Vertical Reinforcement in Cavities

16 Wall Thickness and Spacing

The minimum thicknesses and maximum spacings of masonry walls shall be as described in **Tables 16.1 and 16.2.**

	Height of Wall (m)	Length of Wall (m)	Thickness of Wall at Base (Bricks)
1.	Up to 4.5	Any*	1.5
2.	4.5 to 7.5	Any*	1.5
3.	7.5 to 9	Up to 14 Above 14	1.5 2
4.	9 to 12	Up to 9 9 to 14 14 to 18	1.5 2 2.5
5.	12 to 15	Up to 9 9 to 18	2 2.5
6.	15 to 18	Up to 9 9 to 14	2.5 3

* *Provision should be made for expansion/contraction joints.*

Table 16.1 : Thickness of Walls for Public Buildings, Warehouse and Industrial Buildings

Notes :

- (i) *An additional thickness of one-half a brick at the base will usually be sufficient where vibrating machinery is used.*
- (ii) *The base thickness is reduced towards the top; for 5 m from the top of wall, the thickness should be 1.5 bricks, but where the wall does not exceed 9 m in height, the wall for 3.5 m from the top may be one brick thick if the wall is in a cement mortar.*

	Thickness of Load-Bearing Wall to be Stiffened (mm)	Height* of Storey not to exceed (m)	Stiffening Wall*		
			Thickness not less than (mm)		Max. Spacing (m)
			1 to 3 storeys	4 to 6 storeys	
1.	100	3.2	240	-	4.5
2.	240	3.2	360	480	6.0

*Storey height and maximum spacing are given as centre-to-centre dimensions.

Table 16.2 : Thickness and Spacing of Stiffening Walls